

VersaLite MedDrawer

Versatile, simple, and secure storage workstation



 Lithium-ion battery*

 Electric height adjustment*

SmartPower
option
available

This cart is designed to be used with different computers and devices. Our medical-grade Infinity all-in-one PC is shown on the cart above and features:

- A large, intuitive touchscreen.
- Dual hot-swappable batteries for 24/7 constant power.
- Powerful CPU, ultra-fast SSD and up to 64GB system memory.
- Unique battery management software with remote monitoring.
- Front panel is IP65 rated for protection from water and dust.
- 3-year warranty.

For more info on our Infinity all-in-one PCs or to enquire about a cart bundle package, please get in touch with our sales team, who will be happy to help. Our contact details are below.

Compatible with



Infinity
all-in-one PC



Micro
PC*



Laptop

*Requires SmartPower

Features

Our smallest, lightest, height-adjustable ePMA cart is great for providing storage and is easy to move in congested areas.

- ✓ Simple hand-operated height adjustment.
- ✓ Lockable drawer is easy to access quickly when needed for more efficient dispensing.
- ✓ Modular design allows for the addition of a range of accessories and drawer configurations. Digi, keyed, and RFID lock options are available for secure storage.
- ✓ Work surface is durable and resistant to hospital cleaning agents.

Benefits

- Small footprint makes the cart easy to position in busy bays.
- Conveniently placed grab handles allow precise and easy movement.
- Large rear castors provide smooth and stable movement even across uneven surfaces, such as thresholds.
- Designed for infection control and ease of cleaning.
- An ergonomically designed base allows the user to find their perfect standing or seated position.
- Comprehensive 5-year cart warranty.

Areas of use

The VersaLite MedDrawer is ideal for providing access to electronic patient records or medication notes in areas such as:

- A&E / ED
- Theatres
- Wards

VersaLite MedDrawer

Versatile, simple, and secure storage workstation

Drawings

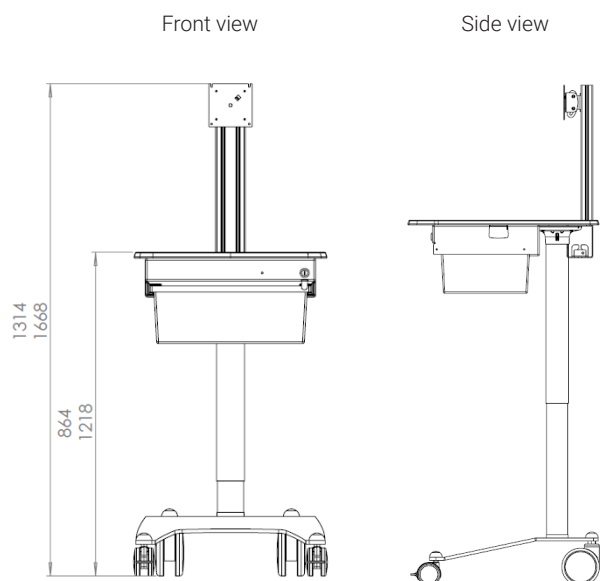

View from above

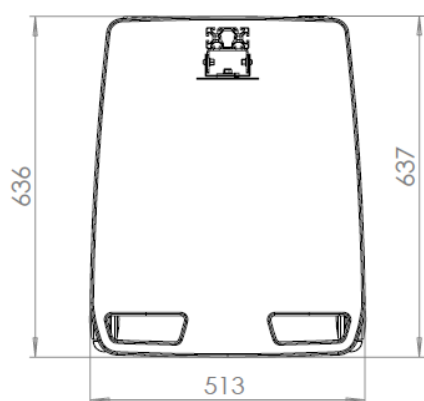

Main specifications

Work surface height (extended)	1218 mm (unpowered) 1223 mm (powered)
Work surface height (compressed)	864 mm (unpowered) 923 mm (powered)
Weight (base cart only)	31 kg
Weight (base cart with SmartPower)	46 kg
Work surface dimensions	513 mm (width) x 636 mm (depth)
Unpowered cart base dimensions	515 mm (width) x 627 mm (depth)
Powered cart base dimensions	505 mm (width) x 642 mm (depth)

Approved cleaning solutions

- Quaternary ammonium chloride compounds (such as AirX109)
- Bleach-Household strength (1:10 minimum dilution strength)
- Ethyl or Isopropyl alcohol-70%
- Hydrogen Peroxide
- Phenolic disinfectants (such as Lysol, WexCide)
- Ovation
- Fantastic
- Formula 409
- 1.6% Aqueous Ammonia
- "Green Soap" USP (United States Pharmacopoeia)
- Clinell Wipes
- Chlor Clean



Direct purchase



Made in the UK



Project management



Device configuration



Phased delivery



Instant support

Common accessories



Printer



Scanner



Medical keyboard & mouse

Version 2.0

