

Genna

Robust, reliable and secure storage for ePMA

Features

A height-adjustable cart with a generous storage capacity, a large worksurface for medicines prep, and an unique, ergonomic design to enhance accessibility to patient information and IT hardware.

- ✓ Electric height adjustment to change height at the touch of a button.
- ✓ Secure, organised storage with up to five drawers reduces the need for restocking.
- ✓ Integrated bottle drawer allows for liquid medication to be stored separately on two levels.
- ✓ Retractable keyboard conveniently tucks out of the way during medication prep and dispensing.
- ✓ Work surface is durable and resistant to hospital cleaning agents.

Benefits

- Small footprint makes the cart easy to position in busy bays.
- Large work surface and slide out tray provide ample medication preparation space.
- Conveniently placed grab handles at the side of the cart provide an unobscured view when moving the cart to a new area.
- The wider work surface design offers protection from damage for your screen while being moved to a new area.
- LED battery gauge at front of cart provides an at-a-glance view of battery power status from across the room.
- Easily accessible PC enclosure and cable management.
- Side rail provides versatility for mounting a range of accessories, such as label printers, barcode scanners and sharps bins.
- Designed for infection control and ease of cleaning.

Areas of use

This ePMA cart is ideal for providing access to electronic patient records as well as secure access to medication in areas such as:

- A&E / ED
- ICU
- Theatres
- Wards



This cart is designed to be used with different computers and devices. Our 24" medical-grade Infinity all-in-one PC is shown on the cart above, which features:

- A large, intuitive touchscreen
- Dual hot-swappable batteries for 24/7 constant power
- Powerful CPU, ultra-fast SSD and 16GB memory
- Unique battery management software with remote monitoring
- Front panel is IP65 rated for protection from water and dust

For more info on our Infinity all-in-one PCs or to enquire about a cart bundle package, please get in touch with our sales team, who will be happy to help. Our contact details are below.

Compatible with



Infinity
all-in-one PC



Micro
PC



Laptop

Genna

Robust, reliable and secure storage for ePMA

Drawings

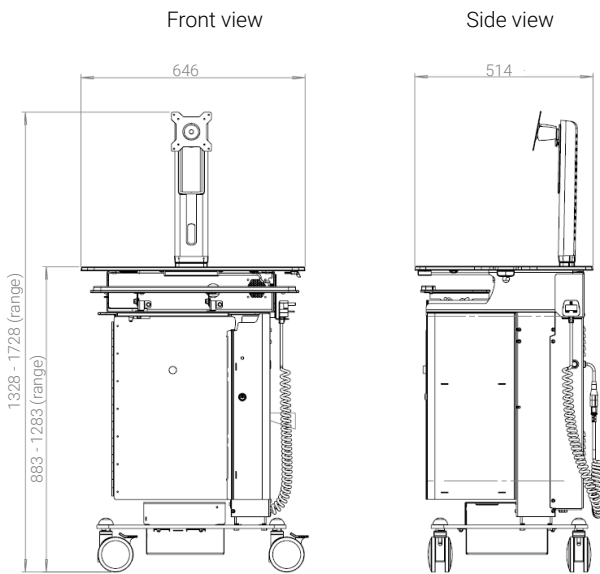

PC caddy tray location and dimensions

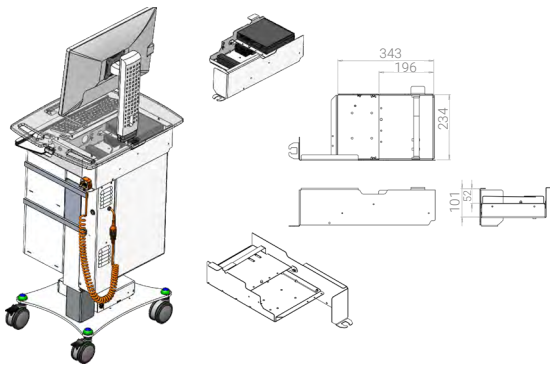

Main specifications

Height (extended)	1283 mm
Height (compressed)	883 mm
Work surface dimensions	646 mm (width) x 514 mm (depth)
Weight (cart base only)	75 kg
PC caddy dimensions	386 mm (width) x 234 mm (depth) x 103 mm (height)
PC shelf dimensions	198 mm (width) x 234 mm (depth) x 49 mm (height)

Approved cleaning solutions

- Quaternary ammonium chloride compounds (such as AirX109)
- Bleach-Household strength (1:10 minimum dilution strength)
- Ethyl or Isopropyl alcohol-70%
- Hydrogen Peroxide
- Phenolic disinfectants (such as Lysol, WexCide)
- Ovation
- Fantastic
- Formula 409
- 1.6% Aqueous Ammonia
- "Green Soap" USP (United States Pharmacopoeia)
- Clinell Wipes
- Chlor Clean



Direct purchase



Made in the UK



Project management



Device configuration



Phased delivery



Instant support

Common accessories



Printer



Scanner



Medical keyboard & mouse

