

# UltraLite Laptop Cart

## Access patient data anywhere in the Hospital.

The UltraLite Laptop Cart is the smallest, lightest Cart in our range. The perfect choice for congested areas where space is at a premium.

### Built for mobility

- Easy to manoeuvre in even the tightest spots: Ultra-lightweight, with a small footprint.
- Robust and stable: Metal construction with a composite work surface. Hospital-grade castors keep the cart stable even manoeuvring over thresholds. Front two castors lock to ensure the Cart remains stationary when in use.

### Designed for individuals

- Simple one-handed height adjustment allows the user to find and maintain their perfect standing or seated posture.
- Retractable mouse tray for left or right-handed use.
- Space under the work surface for notes or gloves etc.

### Perfect for infection control

- Smooth profiles (no nooks or recesses) and concealed cables mean the Cart is quick and simple to clean using standard Hospital wipes.

### Choice of laptop bracket:



Adjustable



Standard

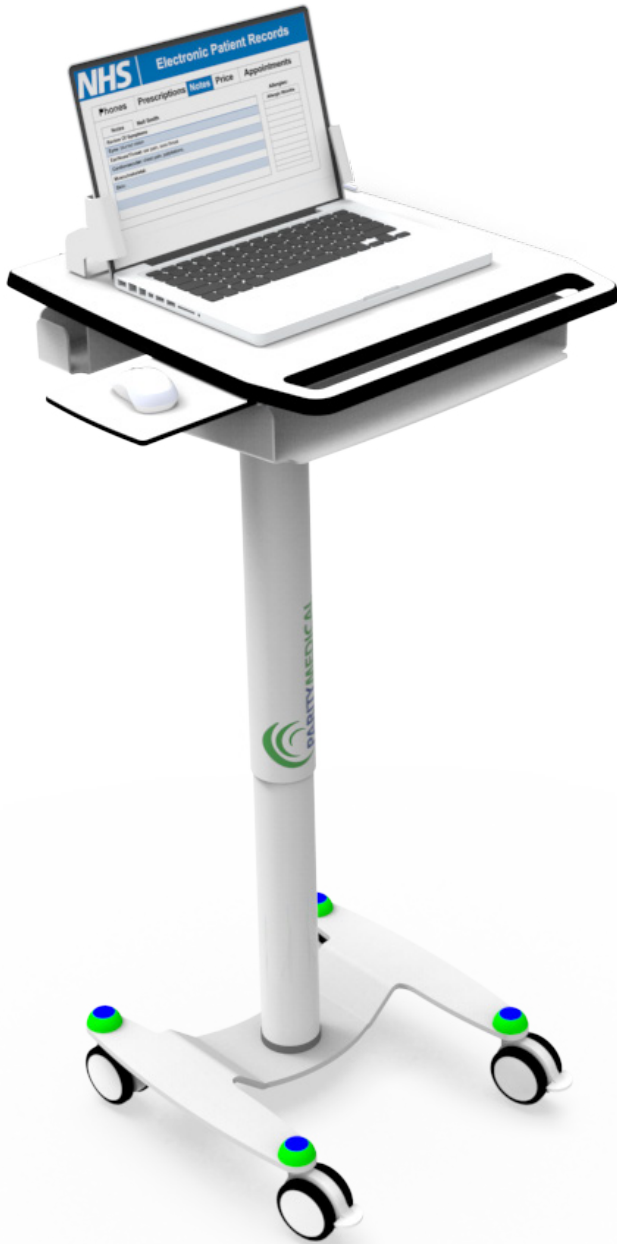

Direct purchase



Made in the UK



Project management



Device configuration



Phased delivery



Instant support

# UltraLite Laptop Cart

Access patient data anywhere in the Hospital.

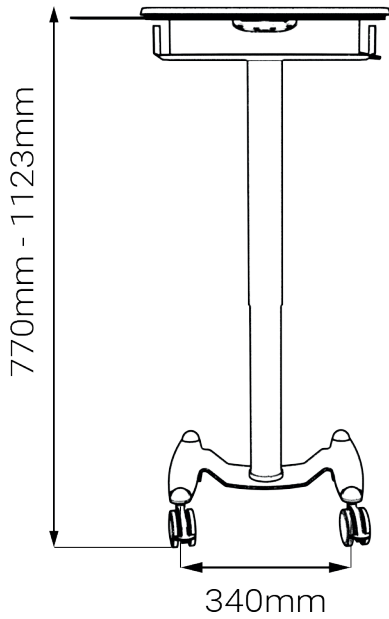

## Dimensions

Height Extended	1123 mm
Height Compressed	770 mm
Base Dimensions	340mm x 340 mm
Worksurface Dimensions	483mm x 424 mm
Weight	18 kg

## Infection control

The Parity Medical range of Carts has been specifically designed to be quickly and effectively cleaned with standard hospital wipes.

We recommend Clinell Universal Wipes. A full list of recommended cleaning solutions is available upon request.

