

Hygia MedStore Extra Infinity Cart

Enhance ePMA and EPR with ease.



The Hygia Medstore Extra Infinity Cart provides improved workflow efficiency and ergonomic design benefits for ePMA and EPR applications.

- Reduces the risk of prescribing errors by accessing the patient record at the point of administration.
- Hot-swappable batteries ensure the cart is available for use 24/7.
- Lightweight design means less strain on dispensing staff.
- Additional bottle storage within the door results in less bending during drug rounds and easy access to liquid medicine.
- Reduced work surface height reduces user back strain.
- Compact footprint for ease of use in busier wards with less free space.
- Robust, lockable construction provides assured medicine security and increased service life.
- Smooth, easy to clean surfaces to meet infection control standards.
- Designed in accordance with BS EN 60601 for strength, moving parts, sharp edges and stability, where applicable.
- Designed specifically for Medication Administration, e-prescribing and Phlebotomy applications.

Accessories



Scanner



Keyboard Mount



Sharps bin



Mobile Printer

Hygia MedStore Extra Infinity Cart

Enhance ePMA and EPR with ease.

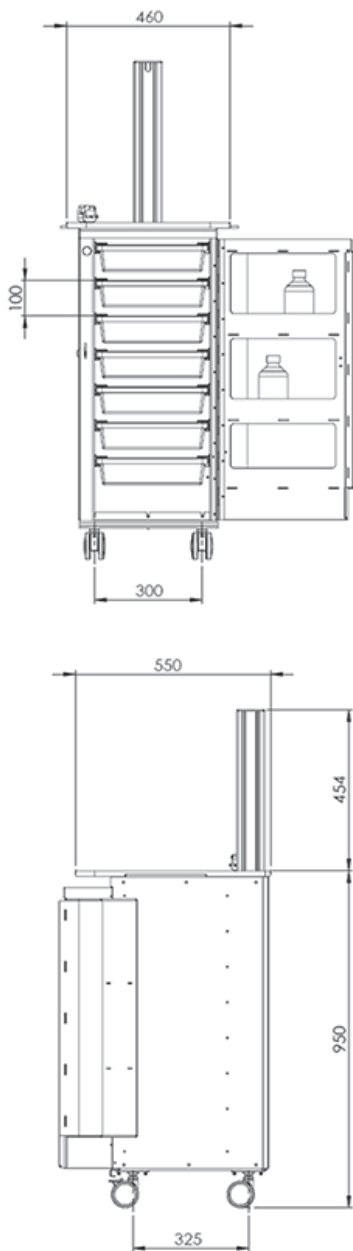

Dimensions

Footprint	300mm Wide x 325mm Long
Work Surface Dimensions	460mm Wide x 550mm Long
Floor to Work Surface	950mm High
Weight	48kg

Approved Cleaning Solutions

Made with materials that are resistant to cleaning solutions, the Cart can be cleaned with most hospital-grade cleaning solutions. An approved list is available on request.

Cart

Work Surface	Large enough to accommodate a full size keyboard and mouse, yet maintains a small overall footprint
Manoeuvring	Contoured handle for ease of manoeuvre
Storage	Large volume of configurable storage space Including options on drawer depth, sample holders, bottle holders, lids separate compartments and more are available.
Drawers	All drawers 'stop' to prevent unintended removal of drawers
Wheels	4x medical grade wheels (2 Locking)
Mouse Tray	The mouse tray can be used in either a left or right position

Security

Key lock	This can be suited to Hospital/Ward for easy key management Economical solution
RFID lock	Keyless entry Maintenance free Future-proof Easily managed
Keypad lock	Keyless entry Changeable entry codes Durable Easily managed

Medically Certified

EN60601	Certified Power Supply
Infection Control	No external fixings No visible vents

All-in-One Computer

Size	19", 22" or 24"
Resolution	1280x1080 (19") or 1920x1080 (22"/24")
View Angle	170°(H)/160°(V) or 178°(H)/178°(V)
Processor	Intel® Quad-Core J1900 / Intel® Skylake Dual-Core i5
OS Support	Windows 7, 8.1 and 10
Power Requirement	AC100 V~240V. DC24V
Operating Temperature	0°C ~ 40°C (32°F ~ 104°F)
Storage Temperature	-20°C ~ 60°C (-4°F ~ 140°F)
Storage Humidity	10%~95% @ 35°, non-condensing
Degree of Protection	Front Panel IP-65 Certified, IP x 1
System Cooling	Fanless
Net Weight	8KG